

Saturn Series

LED Explosion proof mobile light



Ex Mark : Ex d e IIC T5 Gb
Ex tb III C T95°C Db Ip54
IECEX Certification No.:IECEX CQM 16.0005X

★ KHJ-LED Explosion Proof lighting

Features and benefits

1. Soldering steel, robust and durable.
2. Osram LED Source, High efficacy lumen output and high CRI.
3. Increased safety battery box.
4. Two pieces of lead acid batteries battery (24V12Ah).
5. Low surface temperature: Effective heat dissipation.

Applications

1. Suitable for petroleum, petrochemical, refineries, tunnels, power station, rail way industries, etc.
2. Used in drilling site, repair area, etc.

Executive standard:

- IEC 60079-0:2007
- IEC 60079-1:2014
- IEC 60079-7:2006
- EN 60079-0:2012
- EN 60079-1:2007
- EN 60079-7:2007
- EN 60598-1:2008+A11:2009
- EN 55015:2013
- IEC 62321:2008

Division:

- ATEX Zone 1 & 21 and 2 & 22
- Class I Division 1 & 2 Groups A, B, C, D
- Class II Division 1 Groups E, F, G
- Class II Division 2 Groups F, G
- Class III Division 1
- Class III Division 2

Certifications and Ratings:

- Ex d e IIC T5 Gb
- Ex tb IIIIC T95°C Db IP54
- ATEX Compliant
- IECEx Compliant
- ABS Compliant
- CE Compliant
- RoHS Compliant
- IP 54 Rated



★ CHARACTERISTIC DETAILS



The PCBA and power supply are clung to the housing, which can dissipate the heat very fast, then extend the lifespan.



Aluminum alloy enclosure can endure 20J impact.



Explosion proof connector can work with DC 24V directly

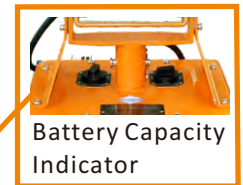

Battery Capacity Indicator



Stepless dimmer design controls the brightness, providing better lighting and extending the working time.



The wheel can be customized as requested.

CHARACTERISTIC DETAILS

★ PERFORMANCE PARAMETER



Product definition

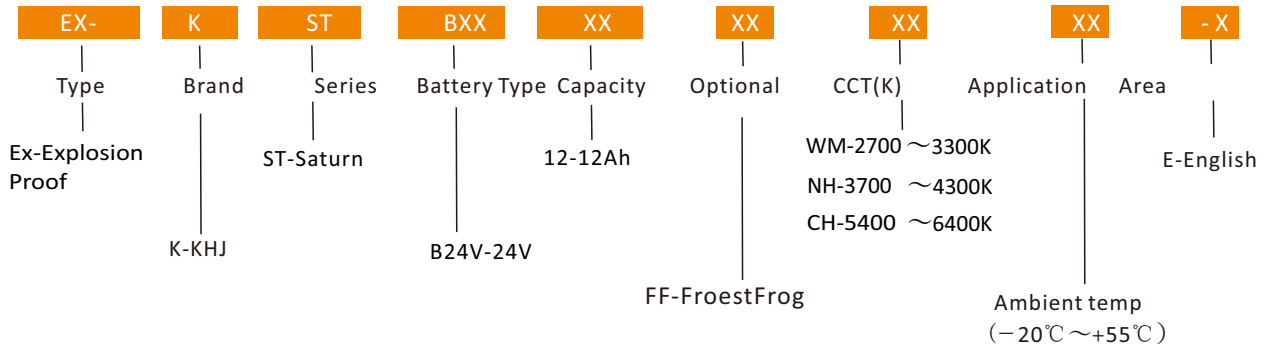

Parameter

Product type		Ex-KSTB24V12FFWM-E	Ex-KSTB24V12FFNH-E	Ex-KSTB24V12FFCH-E
		Warm white	Natural white	Cool white
Ex type		Ex de IIC T5 Gb Ex tb IIIC T95°C Db IP54		
Temp.classification		T5		
Ambient temp.(°C)		-20~+55		
Input voltage(V)		AC 100~240		
Battery	Output voltage (V)	DC 20~30		
	Rated capacity(Ah)	12		
	Type	Lead-acid batteries		
	Lifespan	300 Cycles		
	Working time(h)	15W	12	
		30W	8	
		60W	4	
Charging time(h)(After full discharge)		12~14		
Light	LED Source	OSRAM		
	Power(W)	5~60		
	CRI	82	70	70
	CCT (K)	2800~3300	3800~4300	5400~6400
	Luminous flux(lm)	4541	5676	5676
Size(mm)		350*229*625		
Weight(Kg)		19.5		
IP Code		IP54		
Anti-corrosion		WF2		

★ SIZE



Candela distribution

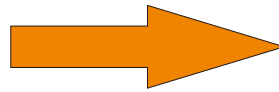
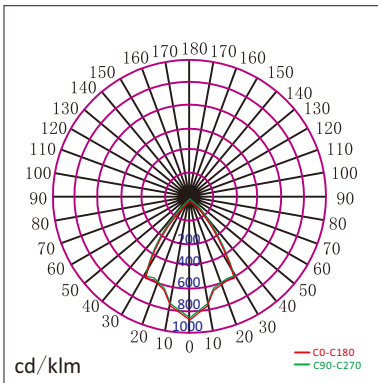

Size

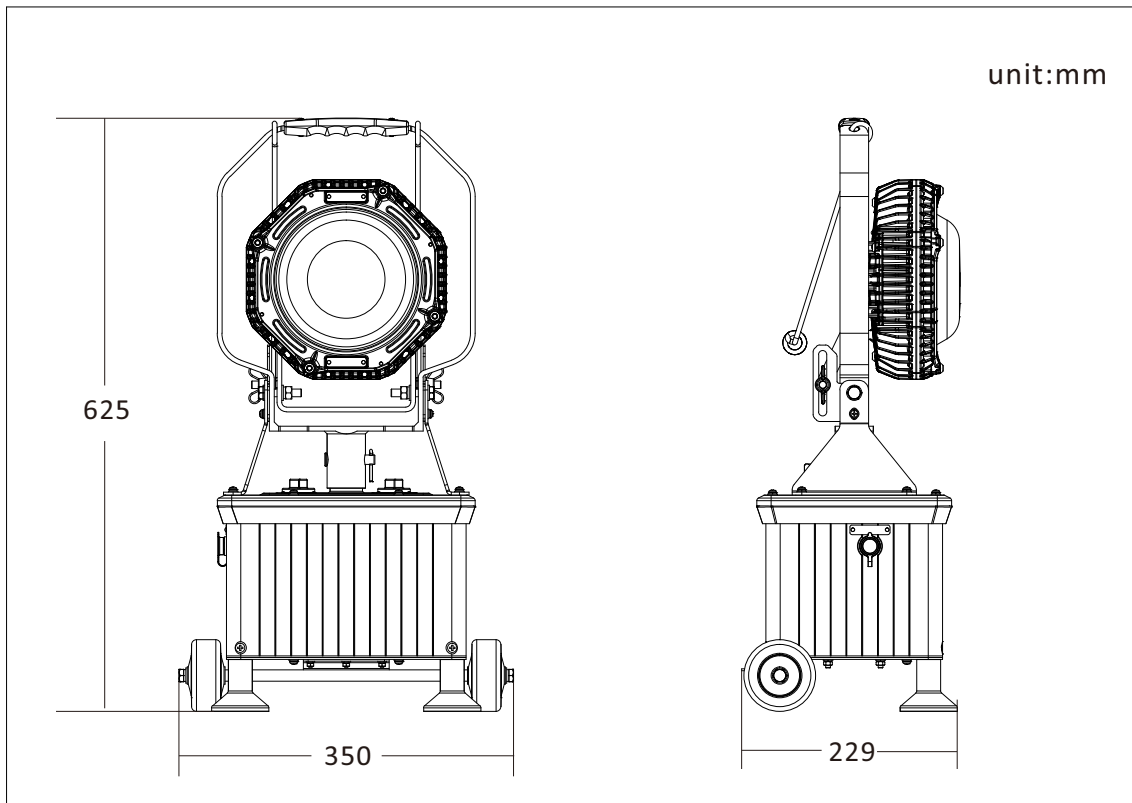

 **Caution**

- 1.To avoid the risk of fire, explosion, or electric shock, this product should be installed, inspected, and maintained by a qualified electrician only, in accordance with all applicable electrical codes.
- 2.To avoid electric shock:
Be certain electrical power is OFF before and during installation and maintenance.
Luminaire must be supplied by a wiring system with an equipment grounding conductor.
- 3.To avoid burning hands:
Make sure lens and housing are cool when performing maintenance.
- 4.To avoid explosion:
 - 1)Make sure the supply voltage is the same as the luminaire voltage.
 - 2)Do not install where the marked operating temperatures exceed the ignition temperature of the hazardous atmosphere.
 - 3)Do not operate in ambient temperatures above those indicated on the luminaire nameplate.
 - 4)All gasket seals must be clean.
 - 5)Before opening, electrical power to the luminaire must be turned off. Keep tightly closed when in operation.

Package Check

- 1.Check the carton and all the components according to the packing list.
- 2.Make sure the product is in good conditions.

Transportation

Please keep this product from heavy mechanical shock, exposure to strong sunshine, throwing, rolling and stress during transport.

Storage

Kept in dry,clean and well-ventilated ,non-corrosive medium warehouse,the ambient temperature should be -40℃ to 55℃.

After-sales service

Installation and maintenance must be according to the instruction.
If customer can not deal with it by themselves ,please contact with sales department.

Contact

SHENZHEN KHJ SEMICONDUCTOR LIGHTING CO., LTD.

Address: 4-5 Floor, Building 1,Chuangxin industrial park,Xintian community,Guanlan, Longhua new district, Shenzhen ,China.

Tel: +86-755-82949977
E-mail: khjledsales@khj.cn

Fax: +86-755-82949800
Web: www.khjled.com